

**GfM. Trendtagung.
Performance Marketing.
Seit 1995. Namics.**

ZÜRICH, 21. MÄRZ 2017

Jürg Stuker. **Partner.**

Automotive AG – Digital Marketing Dashboard / Sample Data

Digital Prospect Lifecycle. Active Platform Users (yesterday).

	201.724	Bouncers	... Description of Audience: Bouncers	▼ -130,261	▼ 1%
	186.600	Explorers	... Description of Audience: Explorers	▼ -62,00	▼ -14%
	241.340	Involved	... Description of Audience: Involved	▲ 2,200	▲ 1%
	83.414	Hot Leads	... Description of Audience: Hot Leads	▲ 10,485	▲ 14%
	38.189	Converters	... Description of Audience: Converters	▲ 1,112	▲ 3%

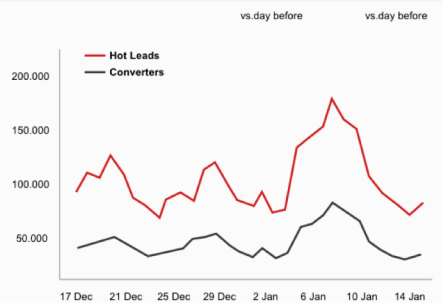
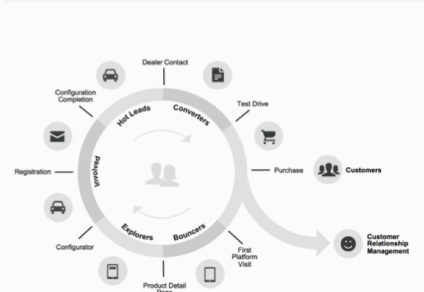

Campaign data (last 30 days).

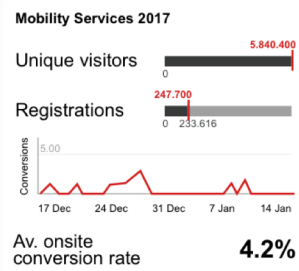
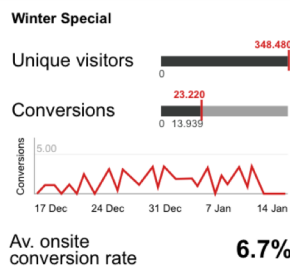
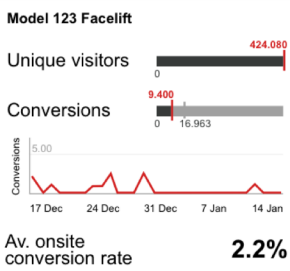

Total Conversions Live Count today:

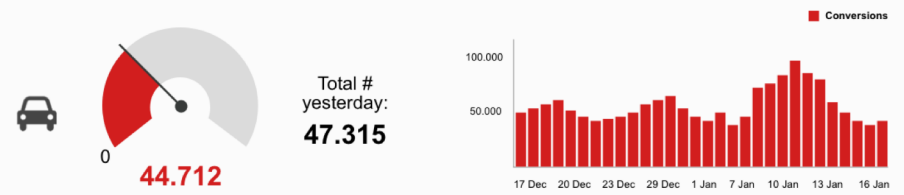

Conversion funnel (yesterday).

Total Visits	100%	843.873	▲ 27%
Car Configuration Starts	55%	466.500	▼ -8%
Returning Visitors	36%	304.922	▲ 9%
Configuration Completions	11%	93.645	▲ 16%
Conversions	6%	47.315	▲ 4%

Conversion (yesterday).

Conversion Type	Conversion	Total Starts	Total Completions	vs. day before	Completion Rate
Test Drive Requests		40,444	3,640	▲ 169	9%
Consultations		15,150	303	▲ 14	2%
Contact Requests		16,856	1,517	▲ 81	9%
Dealer Searches		51,673	41,855	▲ 248	81%

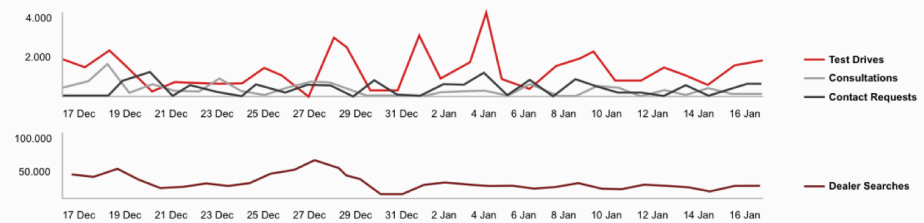





“
Geht es
möglicherweise
um Performance?”

Business Case für Performance

Normale Konversion

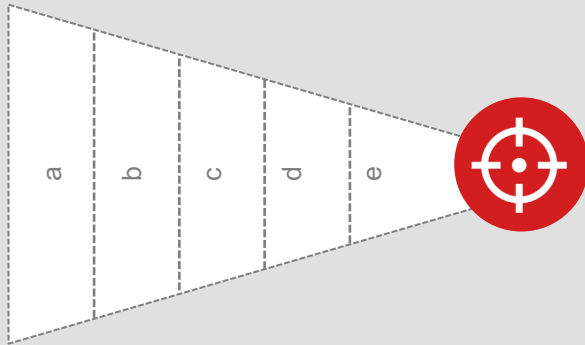

Konversionsnahe Personalisierung

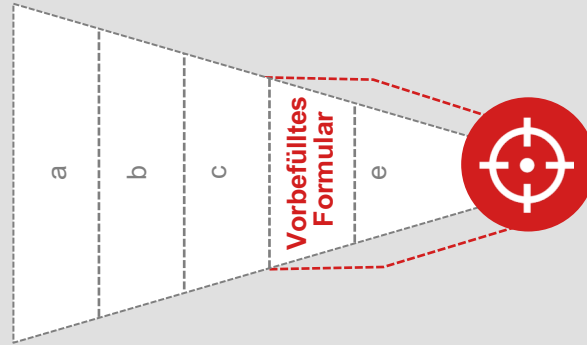

Personalisiertes digitales Marketing

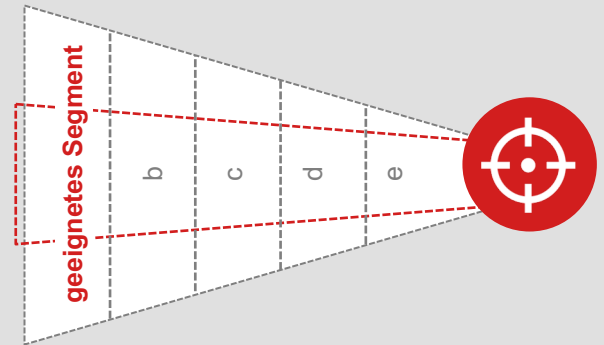



Record-breaking Black Friday Sales to Benefit the Planet

Rose Marcario, CEO | Nov 28, 2016

Activism

👍 71

Last week, when we **announced** we'd give 100 percent of our global retail and online Black Friday sales directly to grassroots nonprofits working on the frontlines to protect our air, water and soil for future generations, we heard from many of our customers calling it a “fundraiser for the earth.”

We're humbled to report the response was beyond expectations: With your help, Patagonia reached a **record-breaking \$10 million in sales**. We expected to reach \$2 million in sales—we beat that expectation five times over. The enormous love our customers showed to the planet on Black Friday enables us to give every penny to hundreds of grassroots environmental organizations working around the world.

Many of these environmental groups are underfunded and

Big Picture des Performance Marketing

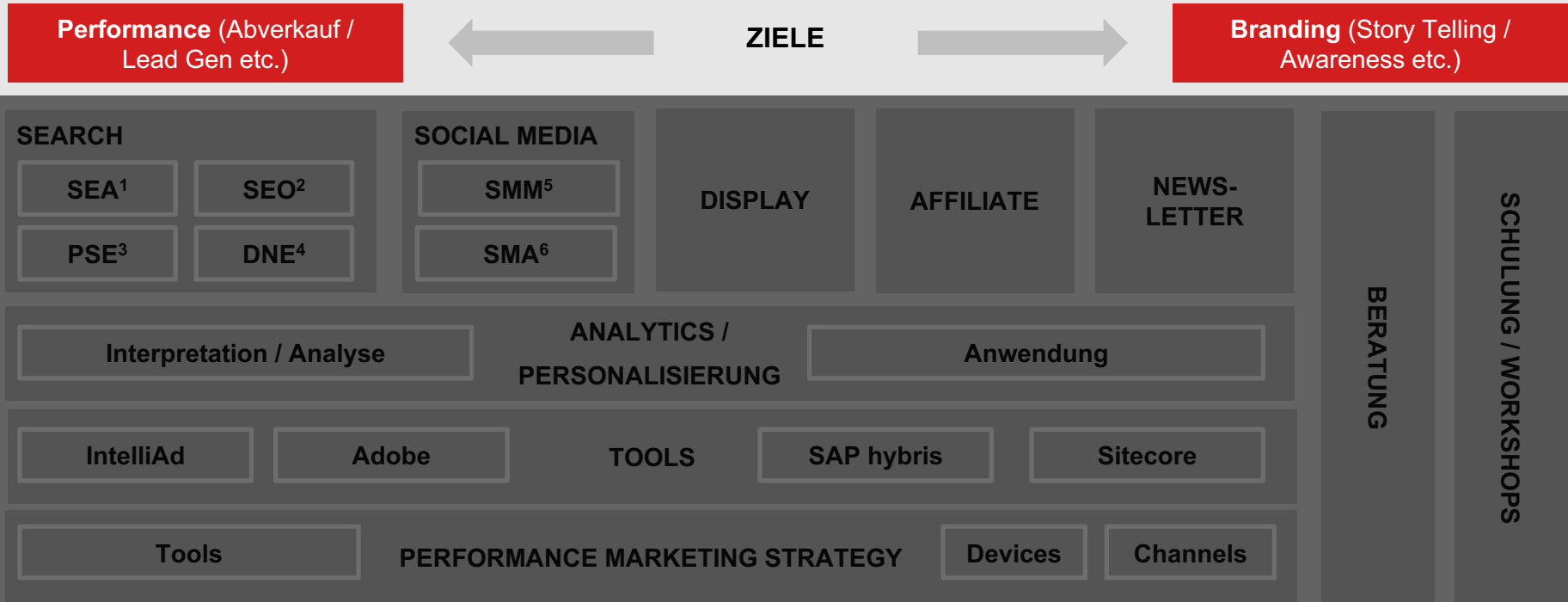

¹ Search Engine Marketing ² Search Engine Optimization ³ Product Search Engines ⁴ Display Networks ⁵ Social Media Marketing ⁶ Social Media Advertising



“

Für neue Sneaker bin ich bereit 200 Franken auszugeben. Kleider kaufe ich aber oftmals auch im Brocki. Das ist gerade Trend und dort findet man einzigartige Kleidungsstücke.

— Maximilian, 17 Jahre, Schweiz

A young man with dark hair, wearing a light-colored jacket, blue jeans, and tan sneakers with white soles, is leaning over a wooden bench. He is wearing large black headphones and has his head resting on his hand, looking down. The background shows a blurred outdoor setting with trees and a building.

“

Ich finde die Leute, in den Youtube-Videos viel kompetenter als das Verkaufspersonal im Laden. Bei den Verkäufern habe ich immer das Gefühl sie wollen das teuerste oder das was ihnen vorgeschrieben wird.

— Adam, 14 Jahre, Schweiz

Die Veränderung

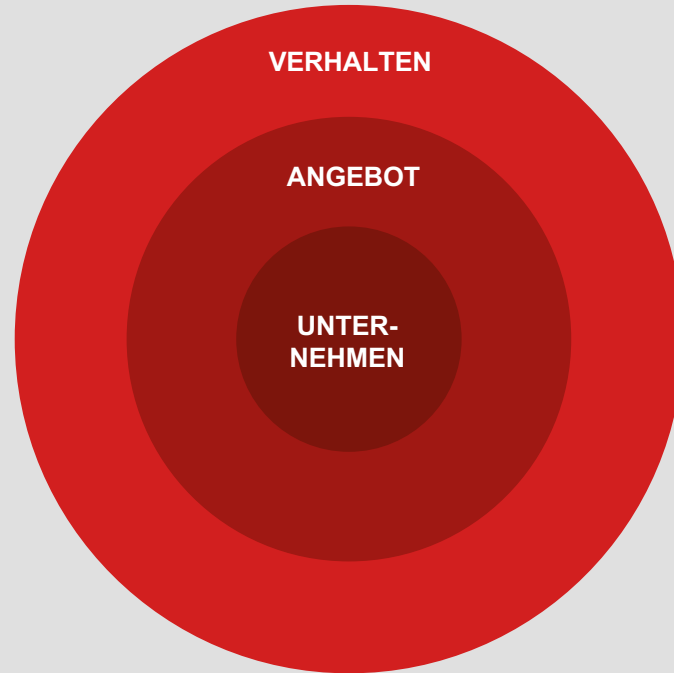

Die Veränderung

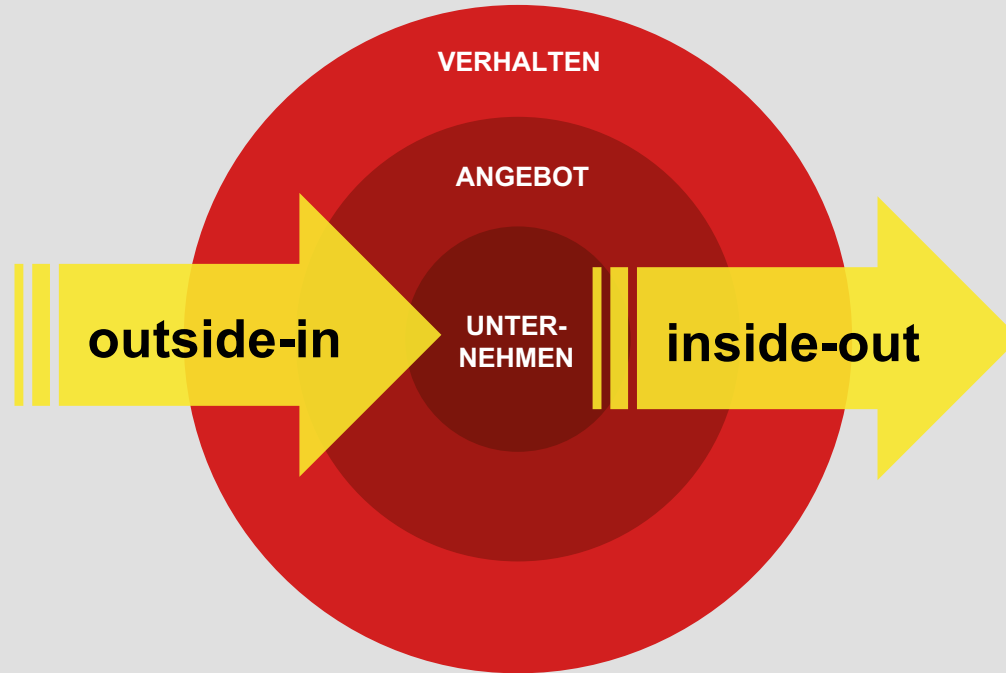

Big Picture des Performance Marketing

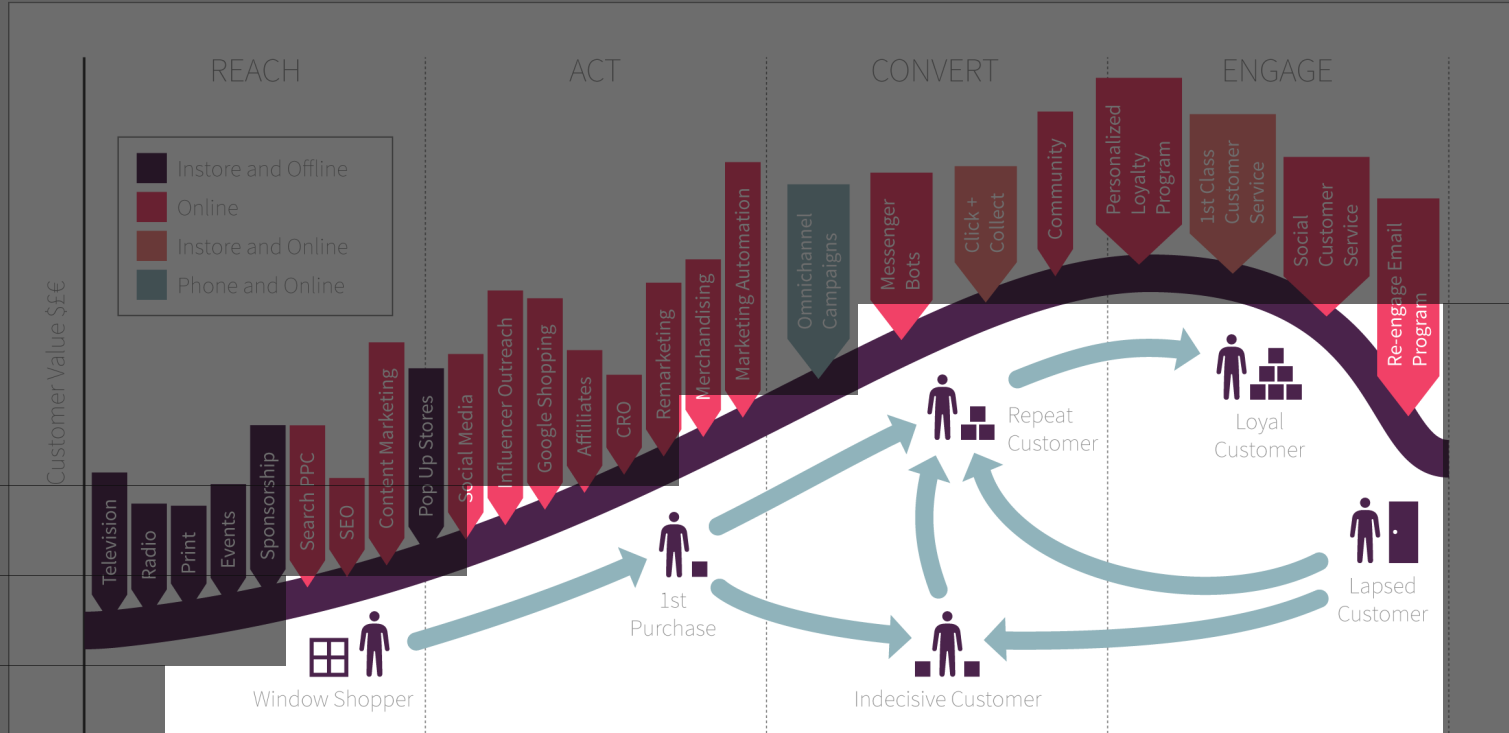





1

These

Langfristig gewinnen Produkte und Dienstleistungen, die aus Sicht der Kunden und “digital first” gestaltet sind.

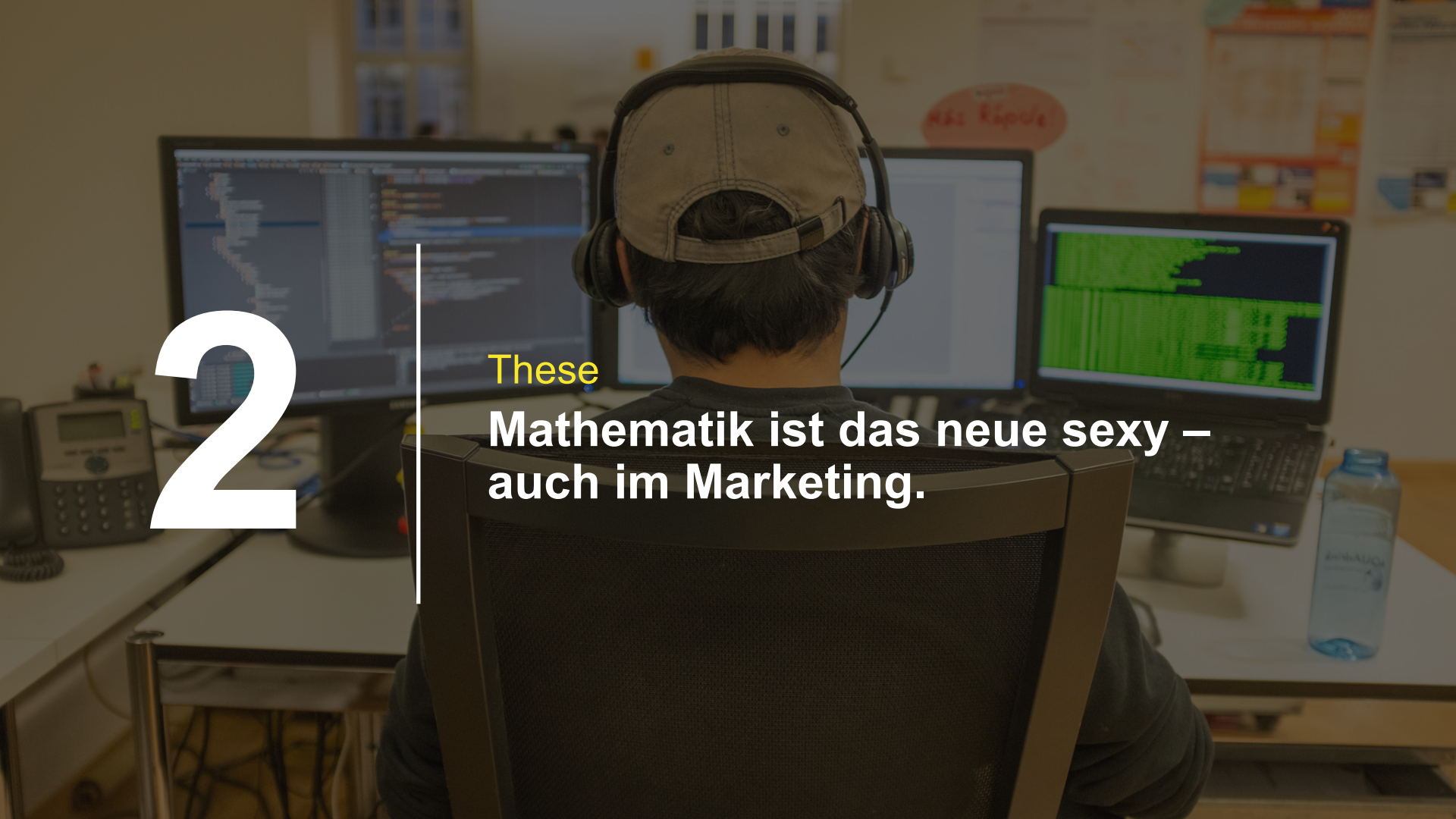

2

These

**Mathematik ist das neue sexy –
auch im Marketing.**

A photograph of two men in conversation. The man on the left is wearing a black tank top, a black bandana with a white paisley pattern, and clear safety glasses. The man on the right is wearing a grey jacket over a light blue shirt, glasses, and a dark green hat with a gold emblem and a blue ribbon. They are standing in front of a light-colored wall with some plants visible in the upper left corner.

3

These

Die Zeit der Querdenker ist
angebrochen.

Tipps für langfristige Erfolge (im Performance Marketing)

- **”Digitale Tauglichkeit”**
- **Alle Kennzahlen in Geld bewerten**
- **Kommuniziert ehrlich und auf Augenhöhe**
- **Segmentierung (und somit auch die Botschaften) sind datengetrieben und kleinteilig**
- **Mitarbeiter und Bestandskunden sind wertvoll**
- **Planung, Bepreisung und Optimierung sind dynamisch**
- **hältet Nachfassstrecken bereit**

GfM. Next Practice.
Let's perform. Namics.

juerg.stuker@namics.com

